



# Diesel Generator Set

## K50 Series

1600 kWe, 2000 kVA



### Reliable and Durable

Cummins® 'K50 series' diesel engine with strong regrindable crankshaft, high strength connecting rod, low pressure fuel lines, ESTC (Step Timing Controls) injectors and high volume coolant system make 'K50 series' generating sets, more reliable and durable. Engines have clocked millions of hours operating in some of the world's most demanding conditions. Current engines are regularly upgraded with new technologies for better performance and economy.

The ultimate proof of superior performance and reliability is the fact that Cummins® entities worldwide source these engines from Cummins India for their markets.

### Unmatched Warranty

Cummins® 'K50 series' diesel engine generating sets are a truly cost effective solution to long term power need backed by industry best, 2 years/5000 hrs warranty, for the entire generating set.

With superior experience in technology, design capability and commitment reliability and quality we offer an unmatched 5 years or 5000 hours (including above 2 years) warranty coverage on 5 critical components (5C) of the engine - Cylinder Head, Camshaft, Crankshaft, Cylinder Block, Connecting Rod against manufacturing defect

### Cummins Advantage

Special features of Cummins® 'K50 series' engines like ESTC (Electrical Step Timing Control) injectors, BCS (Bank Cut off System), low temperature aftercooler, square combustion chamber, optimised turbocharging and precision heavy duty camshaft make these engines the ultimate in exceptional fuel efficiency across the operating range.

### Single Source Power Assurance

Design, manufacture and testing of engine, alternator and other accessories is done by Cummins Group of companies for optimum performance and is backed by a countrywide product support network with a single source responsibility for the entire package.

### Standard Scope

**Engine:** Cummins® 'K50 series' direct injection, water cooled engine, 16 cylinder, 4 stroke, rated at 1500 RPM, conforming to ISO 3046/IS 13018 has the following specifications:

- Cummins PT fuel pump
- Cummins heavy duty ESTC injectors
- Holset turbocharger, pulse tuned exhaust manifold
- Stainless steel exhaust flexible connections
- Radiator & coolant inhibitor
- Plate type lube oil cooler Outboard aftercoolers
- Full flow Spin-on type Lube oil & Fuel filters with Water Separators
- Dry type replaceable paper element air cleaner with restriction indicator
- Flywheel housing & flywheel to suit single bearing-
- Flywheel housing & flywheel size SAE0/18
- Starting motor Electric, battery charging alternator
- Cummins Power Command® microprocessor based genset controller
- First fill lube oil and coolant

**Alternator:** Stamford brushless alternator

- Separately excited, self-regulated -Class 'H' insulation
- Salient pole revolving field
- Single bearing PMG standard
- Space heater & RTD & BTD's only sensor - (without scanner)

**Accessories:**

- Silencer suitably optimized to reduce noise
- Sturdy base rail
- 990 ltrs. free standing fuel tank
- 2 x 12 V dry, uncharged batteries with connecting leads and terminals

## Diesel Generator Set K50 Series

### Optional

**Engine:** Oil/Coolant heater, No cool

**Control Panel:** PC3.3, Power factor, Frequency, Current, Voltage Remote HMI AMF control panel, Battery charger, Remote/Auto start panel, Auto/Manual synchronizing panel, Audio/Visual annunciation for faults, Auxiliary output relays and remote annunciators

### Control panel: PowerCommand® PC 3.3



The PowerCommand control system is an integrated microprocessor based generator set control system providing voltage regulation, engine protection, alternator protection, operator interface and isochronous governing.

**AmpSentry™**-Includes integral AmpSentry™ protection, which provides a full range of alternator protection function which are matched to the alternator provided.

**Power Management** - Control function provides battery monitoring, testing and a smart starting control system.

**Advanced Control Methodology** - Three phase sensing, FET based full wave rectified voltage regulation and a PWM output for stable operation with all load types.

**Communications Interface** - Control comes standard with PCCNet and Modbus interface.

**Regulation Compliant** - Prototype tested: UL, CSA and CE compliant.

**Service** - InPower™ PC-based service tool available for detailed diagnostics, setup, data logging and fault simulation.

**Reliable Design** - For reliable operations in harsh environment.

### Multi-language support

Independent of PC/laptop for setting up  
Operator panel features

**Operator Panel Features** - The operator panel, in addition to the alternator, displays the Utility/ AC Bus data.

### Operator/Display Functions

- 320 x 240 pixels graphic LED backlight LCD with bar graph for displaying electrical parameters
- Auto, manual, start, stop, fault reset and lamp test/panel lamp switches
- Alpha-numeric display with pushbuttons
- LED lamps indicating genset running, remote start, not in auto, common shutdown, common warning, manual run mode, auto mode and stop

### Paralleling Control Functions

- Digital frequency synchronization and voltage matching
- Isochronous kW and kvar load sharing controls
- Droop kW and kvar control
- Sync check
- Extended paralleling (Peak Shave/Base Load)
- Digital power transfer control (AMF) provides load transfer operation in open or closed transition or soft (ramping) transfer mode

## Specification Sheet

### Alternator Data

- Line-to-neutral & line-to-line AC Volts
- 3-phase AC current
- Frequency
- kW, kvar, power factor KVA (three phase and total)

### Engine Data

- DC voltage
- Engine speed
- Lube oil pressure
- Coolant temperature/low level
- Comprehensive FAE data (where applicable)

### Other Data

- Genset model data
- Start attempts, starts, running hours, kW hours
- Load profile (operating hours at % load in 5% increments)
- Fault history
- Data logging and fault simulation (requires InPower)

## Standard control functions

### Digital Governing

- Integrated digital electronic isochronous governor
- Temperature dynamic governing Digital Voltage Regulation
- Integrated digital electronic voltage regulator
- 3-phase, 4-wire line-to-line sensing
- Configurable torque matching

### AmpSentry™ AC Protection

- AmpSentry protective relay
- Over current and short circuit shutdown
- Over current warning
- Single and three phase fault regulation
- Over and under voltage shutdown
- Over and under frequency shutdown
- Overload warning with alarm contact
- Reverse power and reverse var shutdown
- Field overload

### Engine protection

- Battery voltage monitoring, protection and testing.
- Over speed shutdown
- Low oil pressure warning and shutdown
- High coolant temperature warning and shutdown
- Low coolant level warning or shutdown
- Low coolant temperature warning
- Fail to start (over crank) shutdown
- Fail to crank shutdown
- Cranking lockout
- Sensor failure indication
- Low fuel level warning

### Telematics Offerings

- Fault Code Alerts on Email & SMS
- Advisory Services
- Fuel Level Monitoring on Email & SMS
- Multiple Gensets Central Monitoring
- Automatic Reports Generation

## Diesel Generator SetK50 Series

### Control Functions

- Time delay start and cool down
- Real time clock for fault and event time stamping
- Exerciser clock and time of day start/stop
- Data logging
- Cycle cranking
- Load shed/ dump as per configurable priority
- Configurable inputs and outputs (4)
- Remote emergency stop

### Options

- Auxiliary output relays and remote annunciators

## Technical Data

### Generator set specification

Model	C2000D5P
Prime Power Rating kVA	2000
Output Voltage and Frequency	415 Volts, 50 Hz
Power Factor	0.8(lag)
No. of phases	3 Phase
Engine specifications	
Make	Cummins
Model	KTA50-G21
No. of cylinders	16 'Vee'
Aspiration	Turbocharged-Aftercooled
Bore and Stroke	159 mm x 159 mm
Displacement	50.3 ltrs
Output- Prime	2334 bhp (1741 kWm)
Fuel consumption @ 75% load	308 ltr/hr
Fuel consumption @ 100% load	411 ltr/hr
Total wet weight (engine + radiator)	7967 kg
Length X Width X Height (engine)	2772 x 1684 x1800 mm
Compression Ratio	14.7:1
Piston Speed	7.95 mis
Governor/ Class	Electronic / A 1
Lubricating oil system capacity	177 ltrs
Coolant capacity (engine + radiator)	530 ltrs
Combustion air intake @ 100% load (+/-5%)	129 m <sup>3</sup> /min
Exhaust Temperature	487°C
Alternator specifications	
Make	Stamford
Frame size / Model No.	S7L1D-G4
Voltage Regulation	0.50%
Insulation	Class H
Standard Enclosure	IP 23
Winding Pitch	2/ 3 Pitch
Stator Windhg	Double layerlap
Rotor	Dynamically balanced with grade 2.5
Wave form distortion	No load < 1.5%, Non-distorting balanced linear load < 5 %
Telephone interference	THF<2%
Total Harmonic Factor	Better than 2%

## Rating Definitions

### Prime Power Rating (PRP):

Applicable for supplying power to varying electrical load for unlimited hours.

Overload power for PRP applications is restricted. Availability of Overload Power for PRP application will be dependent on operating profile. Consult factory for details.

- Fuel consumption data is based on diesel having specific gravity of 0.85 and conforming to IS:1460
- Fuel consumption tolerance is +5%

### Conformance standards

IS/IEC 60034 -1, IS 1460, ISO 8528,  
ISO 3046, IS 13018, ISO 9001

Typical Open Genset Dimensions

Genset Model	Rating (kVA)	Length (mm)	Width (mm)	Height (mm)	Wet Weight <sub>##</sub> (kg)	Standard Fuel Tank Capacity - External
C2000D5P	2000kVA	5870	2670	3335	13250	990

<sub>##</sub> Approximate Weight

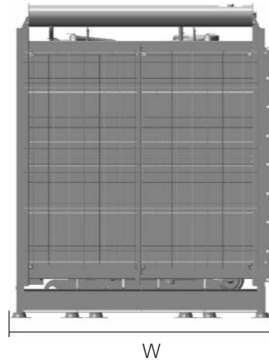
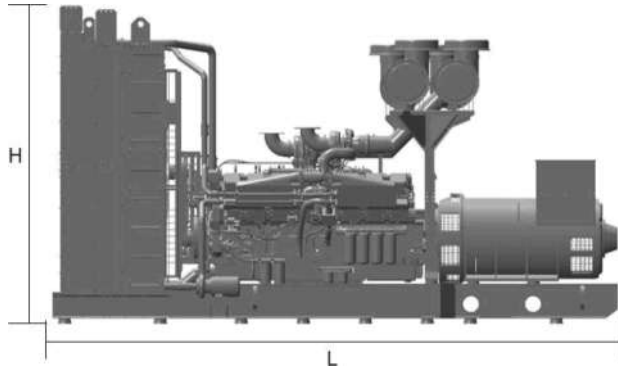

Authorised Representative

**Cummins Power Systems Offices**

- Bengaluru: Tel.: (080) 2325 9161 / 63, 2325 9165 / 67  
Fax: (080) 2325 9164
- Chandigarh: Tel.: (0172) 224 0371-73  
Fax: (0172) 224 0372
- Chennai: Tel.: (044) 2446 8110 / 2446 8113  
Fax: (044) 2491 1120
- Gurgaon: Tel.: (0124) 391 0900-01  
Fax : (0124) 391 0916
- Hyderabad: Tel.: (040) 2340 9970 / 2340 9980  
Fax. (040) 2340 9990
- Jaipur: Tel.: (0141) 236 4944  
Fax: (0141) 403 8794
- Kolkata: Tel.: (033) 2287 8065 / 2287 2481  
Fax: (033) 2290 3839
- Lucknow: Tel.: (0522) 230 5049 / 230 5059  
Fax: (0522) 230 5035
- Mohali: Tel.: (0172) 224 0371 / 72 / 73  
Fax: (0172) 224 0371 / 72 / 73
- Vadodara: Tel.: (0265) 233 0627 / 3053627  
Fax: (0265) 234 0623



Visit our facebook page at :  
Cummins Power Generation India

**“Our energy working for you.”**



Cummins is registered trademarks of Cummins Inc.  
Specification are subject to change without notice.  
PSBU/020/K50/2000 kVA/Rev-01 (08/2022).



**Cummins India Limited  
Power Systems Business**  
Cummins India Office Campus  
Tower-A, 8<sup>th</sup> Floor, S. No. 21,  
Balewadi, Pune – 411 045 (India)

Email: [cpgindia@cummins.com](mailto:cpgindia@cummins.com)  
[www.cumminsindia.com](http://www.cumminsindia.com)